

# Sierra Products PTY LTD Evaporative Air Cooler Owners Manual

Free call: 1800630116 E-Mail: [sierra@bendigo.net.au](mailto:sierra@bendigo.net.au) Web: [www.sierraproducts.com.au](http://www.sierraproducts.com.au)

P.O.Box 1168  
Kangaroo Flat Vic 3555  
Tel: (03) 54413388  
Fax: (03) 54417833

ABN: 76078600450

**Read and save these instructions.**

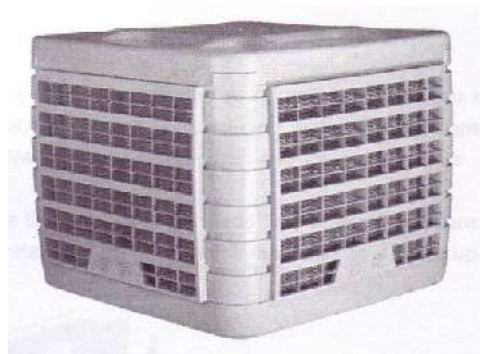

Read all instructions carefully before setting up and operating this unit.

This manual is designed to provide you with important information needed to setup, operate, maintain, and troubleshoot your cooler.

Failure to follow these instructions may damage and/ or impair its operation and void warranty.



**Preface**

Thank you for selecting Sierra Evaporative Cooling for all your cooling requirements.

Sierra has adopted the most advanced evaporative cooling technology in the world and the contemporary production management system, this installation manual is specific for 18APV (JH18AP- 14D3) evaporative air cooler. To ensure the optimal efficiency, we recommend you to read the manual carefully before use.

### **How Evaporative Cooling Works**

Evaporation cooling is to cool and humidify air by water evaporation to absorb heat. Do you ever wonder why you feel cooler by the ocean? It is because hot air is blown over water to evaporate and absorb heat. Evaporative air coolers work to this evaporation principle.

In an evaporative cooler a circulation pump keeps the cellulose filter pads fully soaked. As warm air passes over wet filter pads water naturally evaporates into the air. The air is cooled as it gives up the heat required to evaporate the water.

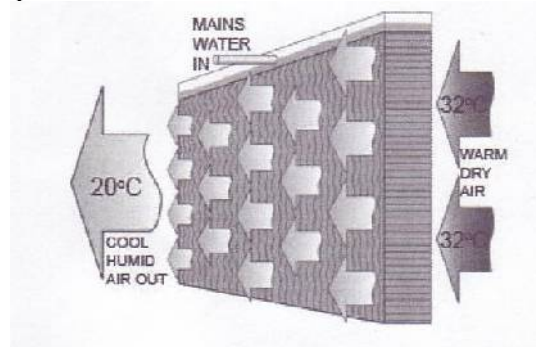

### **Application Areas Of Evaporative Air Cooler.**

#### (1) Relative Dry And Hot Areas.

Most of the areas which need to reduce temperature and increase ventilation can use our products such as malls, supermarkets, office, hotels, gymnasiums, exhibition buildings, restaurants, halls, meeting rooms, schools, factories and domestic homes, the list is endless.

#### (2) Relative Humid Areas

Evaporative air coolers are suitable for the high temperature or in particular factories, such as textile mill, dress mill, printing and dyeing mill, tannery, shoe mill, plastic mill, steel works, electronic manufacture, and chemical plants. You can use our coolers to full cooling. Our cooler is suitable for the fuggy areas such as game or disco parlor, kitchen, refectory or hotel, you can use the cooler for cooling and for venting.

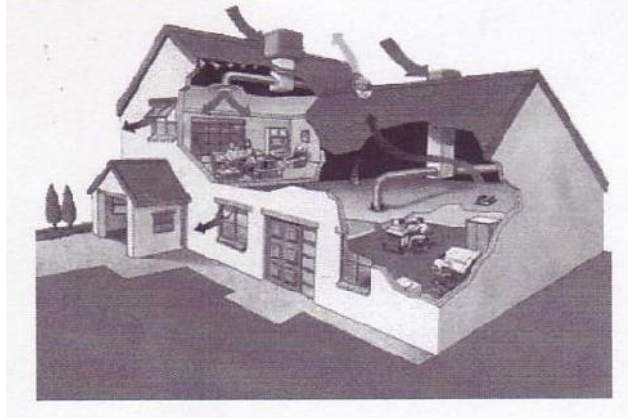

filter

### **Evaporative Air Cooler Features.**

- (1.) Well designed system ensures best cooling effect.
- (2.) Energy efficient environmental friendly, saving more than 80% of electricity as compared with conventional air conditioners;
- (3.) The patented pads has over 90 % of soak rate;
- (4.) High quality sealed aluminum motor, with good sinking effect, IP44 high level protection, stable temperature, water proof and sturdy;
- (5.) The exclusive fan blades produce large airflow and creates little noise;
- (6.) Filter pads are easy to clean and maintain;
- (7.) Patented open- style water diffuser ensures high efficiency and stable water supply;
- (8.) Multi-lever air flow regulator.

### **18APV Technical Details.**

Model No.	JH18AP-14D3
Voltage	220V
Frequency	50Hz
Speeds	16 speeds
Wattage	1100W
Max Airflow	16,500 m <sup>3</sup> /h
Air Pressure	180Pa
Fan Type	Axial
Size of Coolers	1100x1100x950mm_
Size of Air Outlet	632 x 632mm
Size of Cooling Pad	(685+30) *790*100mm
Control Type	RTC wall controller & remote control
Water Tank	40L
Filter Material	Celdek
Effective Area	100-150 Square meters
Net Weight	70.5kg
Gross Weight	80kg

## Spare Parts

Main Components:



Motor:

- High efficiency, low noise, strong power Volume
- Full protection against over current, over voltage and overload.
- Unsurpassed reliability

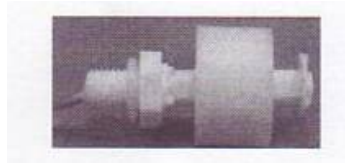

Water Level Probe:

- Water level control
- Precisely and accurately checks the water level
- Device to prevent damage if the circulation pump stops circulating water.

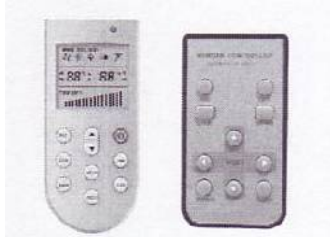

LCD Controller & Remote Control:

- Relative humidity and temperature control wall controller
- To control power supply and components, and implement instructions from the MCU
- A large LCD screen displayed simplifies operations.
- Multi function MCU control system includes a programmed on/off function.

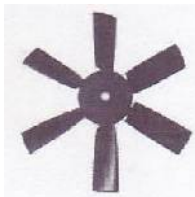

Fan Blade:

- Made up of 6 piece of high- rigid and fibrous plastic
- All pieces can be adjusted to the prefer angle (preset at factory)
- Strong air volume



**Drain Valve:**

- Automatic water draining every 8 hours.
- Prevents algae growth
- Maintains clean unit
- Clean and dry function.



**Inlet Valve:**

- New type, smart designed, permanent magnetic valve
- Small buoy, unsurpassed reliability

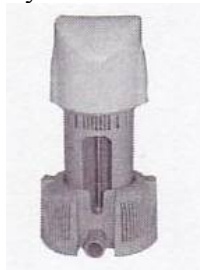

**Water Pump:**

- Professionally manufactured, good heat- radiating performance.
- Permanent magnetic synchro motor inside.
- Powerful, durable, high lift, low noise.
- Exceptional reliability in extreme conditions.

**Check Up and Adjustment Before Operation:**

1. Is the cooler installed horizontally?
2. Is drain pipe connected to the cooler?
3. Is the water supply leaking?
4. Adjust water level in sump?
5. Is the power supply connected correctly?
6. Is the power line for the control panel correctly connected?
7. Is the operation current within the rated range?
8. Is there any foreign objects in the vent?
9. Is the voltage correct?
10. Does the cooler vibrate noticeably while operating?
11. Is there any foreign objects in the sump?

### **Important Notes:**

1. The best effect is achieved when the unit is used in a well ventilated and dry place, where the unit takes 100% fresh air from outside and no re-circulation occurs.
2. Avoid discharging cool air into a closed space. There must be enough space for discharged air, even use exhaust fans.
3. For a place without powered exhaust, 0.8m<sup>2</sup> of exhaust area is needed for every 3600 m<sup>3</sup>/h air discharge. When using a powered exhaust, the designed exhaust shall not be less than 85% of air intake.
4. Keep the unit away from welding sparks or any source of fire during the installation and when the unit is running.
5. The unit must be tested and adjusted. E.G.: adjusting water level floats before operation. Ensure that the unit is operating within the rated electrical currency.
6. Ensure correct wiring of the power and controller. The section in the power socket shall not be less than 1.55mm<sup>2</sup>. The unit shall use a dedicated power line instead of sharing power line with other equipment.
7. Voltage of power supply shall be within 10% vibration from the rated voltage. Lower voltage may cause motor start failure or undue frequent starts and stops. Long- Term low voltage or high voltage will cause damage to the motor.
8. The controller and its wires shall be kept away from strong electronic and magnetic interference, such as a frequency converter, silicon speed and temperature controller, high frequency heater circuit or high motor power. Avoid wiring the power supply lines parallel to these sources. In the case of unavoidability, the power line must maintain a distance of more than 30cm from parallel interference source.

### **Inspection and Preparation Before Installation**

1. Check the components and documentation (E.G. Instructions, certificate and maintenance card) against the packing list. If there is anything missing or damaged, keep it as it was and report to the factory or local distributor.
2. Check the power supply for correct voltage.

### **Ways of installation**

1. Cooler can be installed on the outer wall, with a side diffuser (an electromotive swing air diffuser can be used to cover larger area);
2. Cooler can be installed on the roof, with a multi- side air diffuser penetrate through the roof and into the room;
3. One or more coolers can be installed on the roof or outer wall, each connected to a duct to deliver the cooled air evenly to the room or to the desired area;
4. A number of coolers can be installed on the roof or on the outer wall, connected to a single duct, and with a powered blower in case of necessity.

(1) Wall:

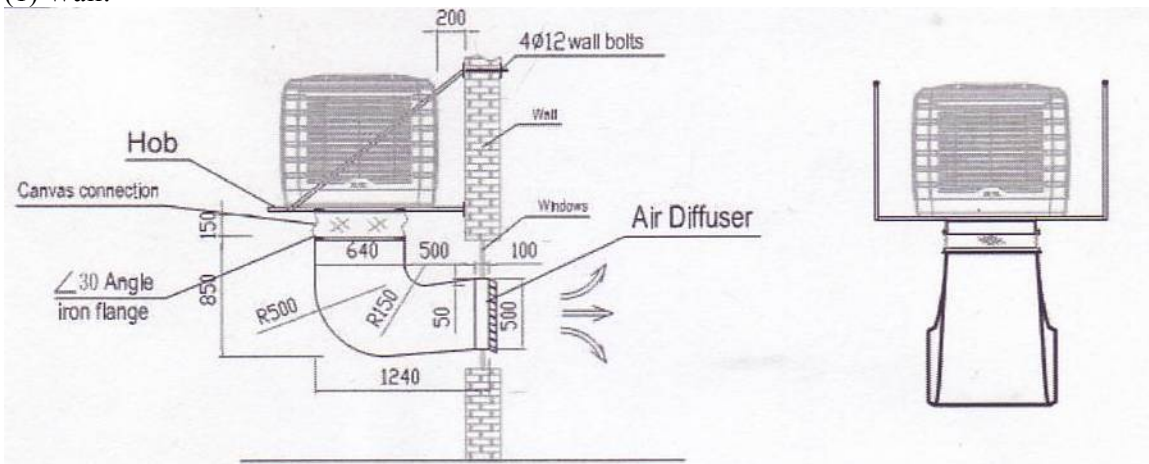

(2) roof:

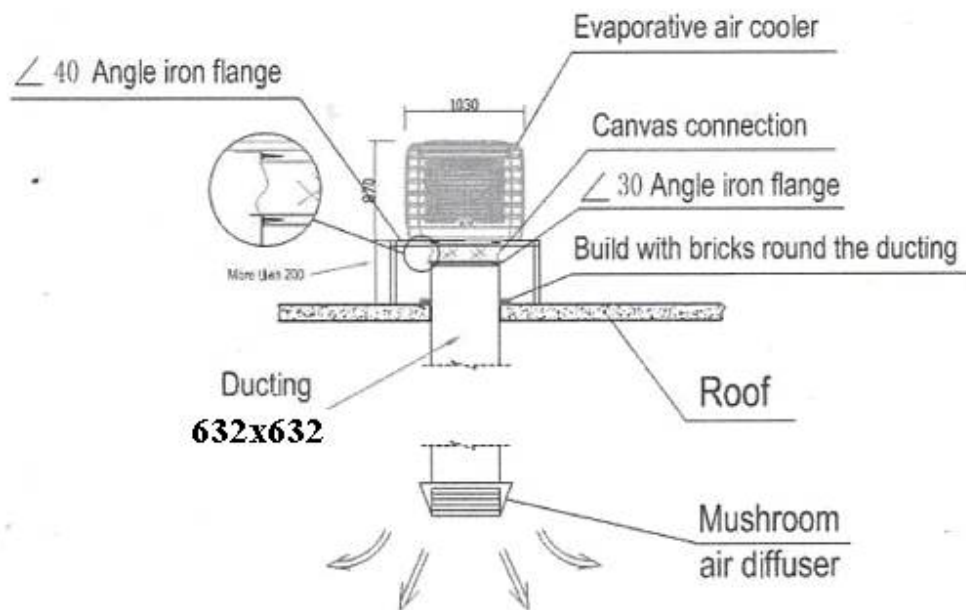

The sketch map of air cooler install in cement roof

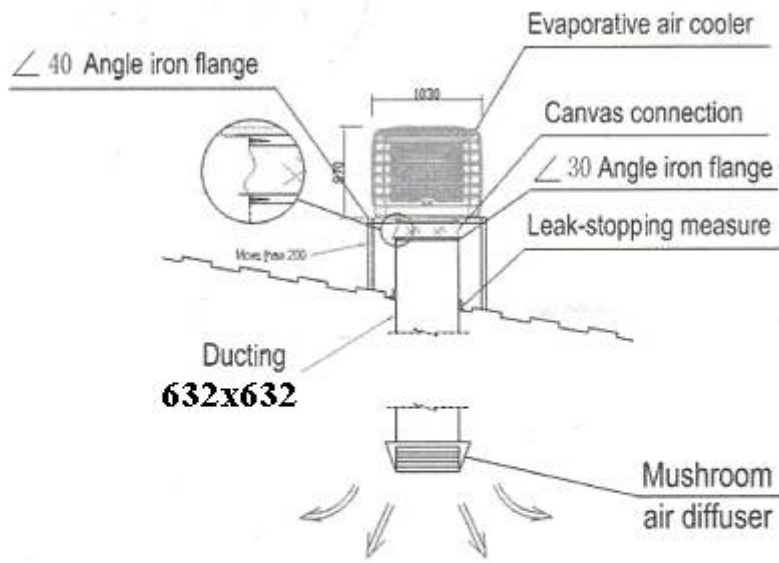

Rooftop installation diagram  
(steel structure, glass tile structure)

(3) diagram of bracket:

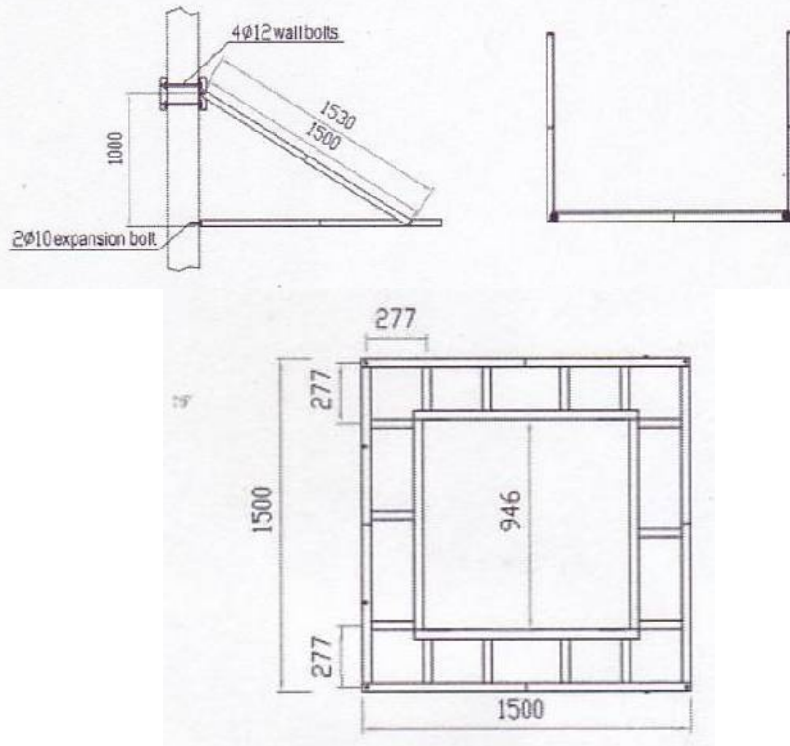

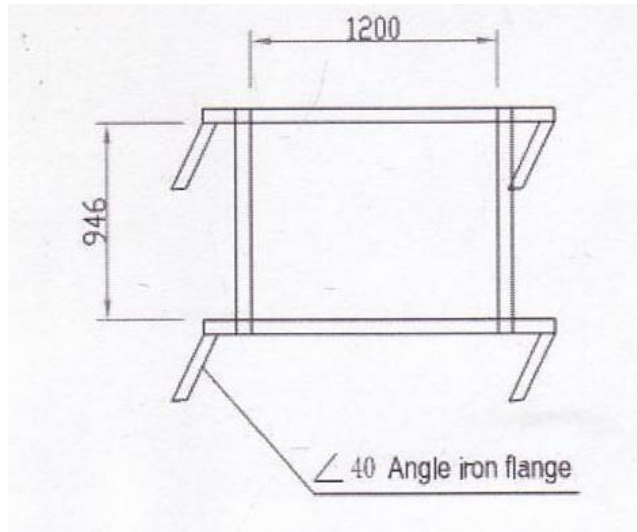

(4) Diagram for duct adaptor

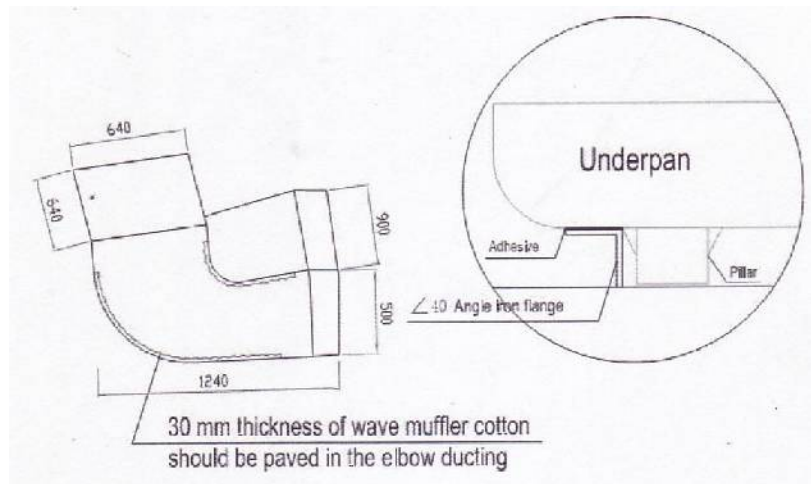

Notes:

As shown above four installation holes at the bottom of the cooler are fixed on the four steel tubes, welded on the bracket to stop the cooler from moving out of place.

## Circuit Diagram Of Control Box Of 18APV

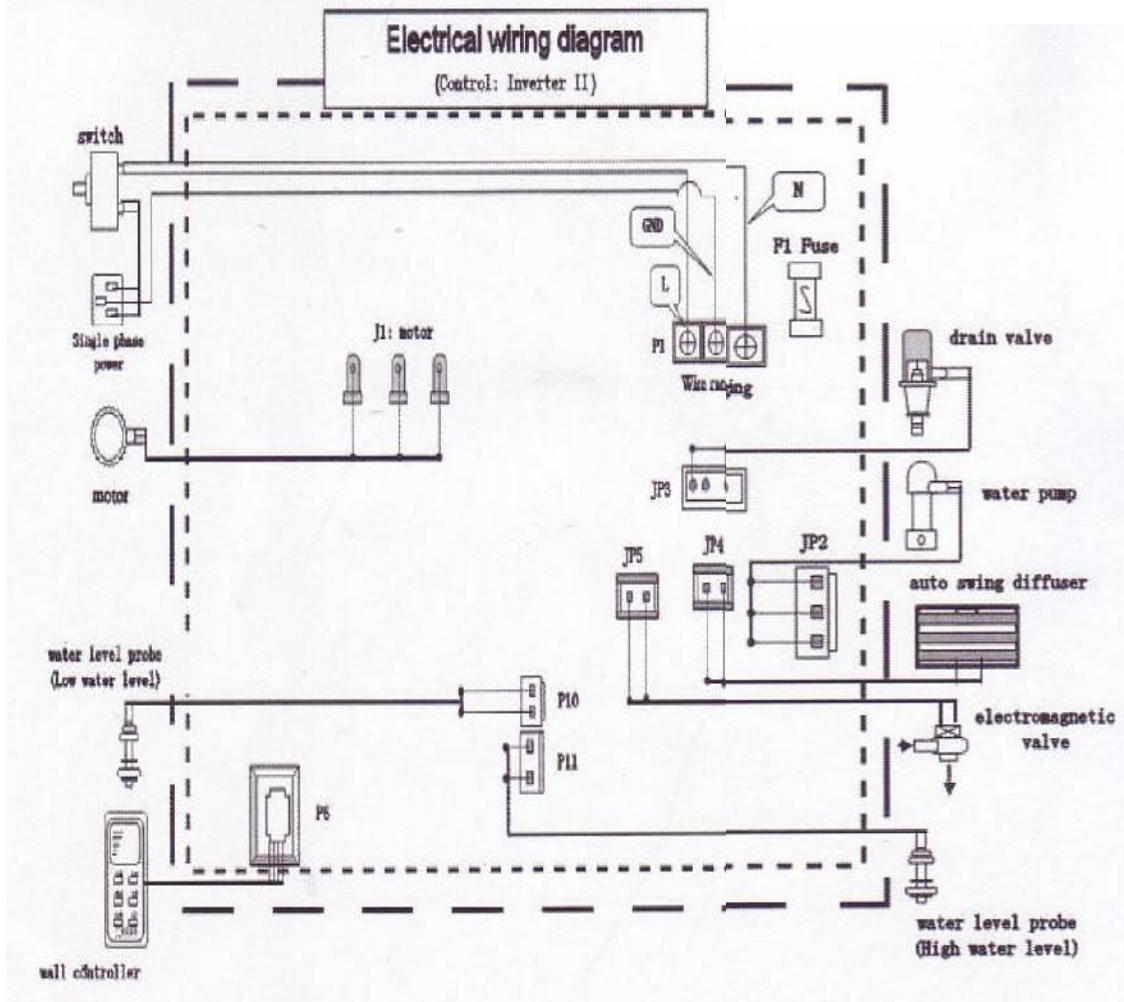

### Tips For Better Duct Work





- (1) The duct uses zinc coated steel, glass steel and plastic duct also can be used.
- (2) The air diffuser should be installed in a places that actually needs to be cooled. It depends on volume and velocity to select the specification of the air diffuser. The air diffuser is made of aluminum, alloy or plastic and the type can be selected according to the actual situation. We recommend both single and double deflection grilles. The average velocity in the duct is supposed to be at 3-6m/s. The air draft can be controlled by a regulating valve.
- (3) The specification of duct depends on flow velocity. The wind velocity in the main duct is kept at 6-8m/s while in the branch is 4-5m/s and 3-4m/s in the end.
- (4) The duct system is required to be economical and to be kept smooth as well as quiet, which makes the perfect air draft. To reduce flow resistance, the elbows radius of curvature is not less than 1.5 times the width of duct.
- (5) The air duct should not be too long, the maximum length is 20m.
- (6) Keep the duct in a straight line is much better. To reduce the pressure drop, keep elbows and branches to a minimum.
- (7) Try to use motor driven diffuser in the plan layout. The air duct should be designed as short as possible in some places where air duct must be applied.
- (8) According to the volume air, different specification of the duct is used in different sections.
- (9) If there are branches in the design, a valve and verge board can be used to control the air volume to reach the design requirement

## **Operating Approach Of RTC LCD Controller.**

### **1. Setting The Clock**

Set the clock on the wall controller before proceeding with any other programming.

The clock can only be set with the wall controller switched  (to prog.)

- a. Press the  button, the hour will flash. The clock can be set to either 12 or 24 hours. If the clock is set to 12 hours, make sure the AM/PM displayed on the screen is correct. AM/PM displayed on the screen is correct. AM/PM will change with adjustment of the hour.
- b. Use the  buttons to change the hour. To change the minutes, press the  button again. Change the minutes using the  buttons.
- c. To lock in the time setting, press the  button, the display will stop flashing. The screen shows the current mode to manual mode, indoor temperature of 27°, humidity of 56%, now is the time 16:35. as per illustration no. 7.1 page 13.

### **2. Turn On/ Turn Off**

The wall controller is switched on and off using the  button. The memory will store and use the setting from when the cooler was last used.

- (a) When turning on the cooler, the pump will work for one minute firstly to pre- wet the cooling pads, and rinse out the dust on cooling pads.  
When turning the cooler off, all functions will close, no other information will be displayed on the screen.  
Note:
- (b) When turning the cooler off, the following settings will be memorized and continue the settings for next time.

(MODE) (TIME FORMAT) (FAN) (COOL) (SPEED) (TEMPERATURE SETTING)  
(CYCLE OF AUTO CLEAN)

- (c) Hold  button down for 5 seconds, the wall controller will get back to the ex- factory setting, restart.

### **3. Fan**

The  button is used to select VENT (when fresh air is being delivered without being cooled).

Once  has been selected, the wall controller will maintain a constant fan speed. This is indicated by the bar graph in the bottom of the display.

To increase or decrease the fan speed, press either the  buttons.

#### 4. Cool

COOL function will make the pump start to work, this will start to pump the water from the tank to wet the cooling pads. Cooled air will be delivered.

When you press the  button and if the water level on tank is too low, the pump will stop running until there is enough water in the tank, this is to protect the pump.

Note: Even the COOL function is running, the pump will also stop if there is a lack of water, this is also to protect the pump.



#### 5. Drain

Pressing the  button, the drain function is turned on, this empties the water in the tank. This will leave the tank clean and dry, it takes approx 5 minutes and will stop automatically. When draining, the water level will decline rapidly, so if the COOL function is still keep on, the pump will pause automatically in order to protect the pump, and start running again when DRAINING stops and the tank has been refreshed with clean water.

#### 6. Auto Cleaning

When FAN and COOL functions work together for N hours (N can be set), air cooler will open the cleansing, drain out the dirty water in tank, and add water automatically.

The default of Auto- cleaning on wall controller is 08 hour.

Press  button to set up auto cleaning cycle, press  for 3 seconds, the Auto Cleaning cycle will be 00 → 04 → 08 → 16 → 32 → 48 → 00 (in hours)

When set on auto cleaning cycle, the screen will show the cycle of auto cleaning (as show in picture 6-1), auto cleaning cycle is 08 hour. The time will disappear when setting finished.

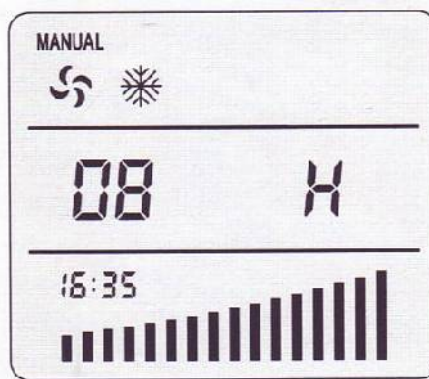

Picture 6-1 Auto-cleaning cycle setting

## 7. Mode

**Note: This Feature does not apply to all models, it will be taken effect only for evaporative air coolers with relative humidity and temperature detecting functions. If your controller does not support the relative humidity and temperature detecting functions, it will show 00° and 00% on screen.**



button can switch air cooler's working modes, that is manual, Auto °C, Auto%

### 7.1 Manual Mode

With the wall controller on, press the  button until MANUAL is shown in the top left corner on the display. Current temperature and relative humidity will be shown on the screen. As per page 11, 7.1. If FAN is selected, the wall controller will maintain a constant fan speed, this is indicated by the bar graph on the bottom of the display. As per page 11, 7.2.

When there is enough water in the tank, press  this will turn on or turn off the pump.



Picture 7-1 Standby condition on MANUAL

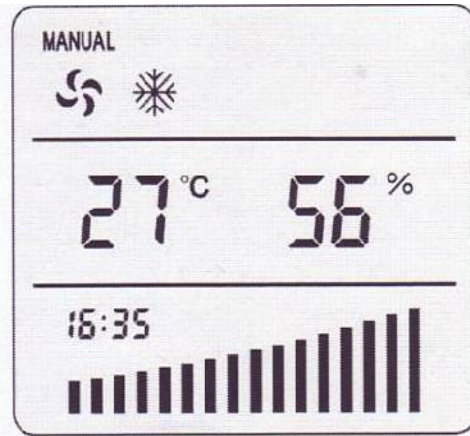

Picture 7-2 FAN and COOL on MANUAL mode

### 7.2 Auto Mode



On the mode of auto, the wall controller will adjust fan speed and pump's work to maintain pre- concerted temperature.

When the mode is switched to auto, the icons of auto, fan and cool will be shown on

the screen, fan and cool functions will be turn on automatically, use  buttons to change speed.

As shown in picture 7-3, current temperature is 27°C, pre-concerted temperature is 25°C, fan and cool functions been turned on.

The default temperature on auto mode is 25°C, if you want to change that, then can press

 button, the pre- concerted temperature flashes, use  buttons to change, press

 button again, this will finish the setting ( as shown in picture 7-5).

the temperature has been changed to 23°C.

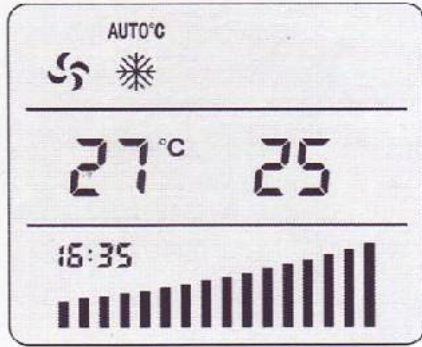

Picture 7-3 AUTO°C mode

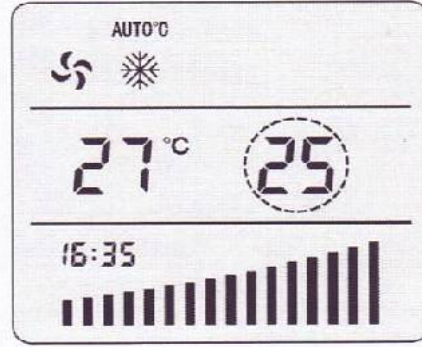

Picture 7-4 setting temperature



Picture 7-5 Finish the setting

### 7.3 Auto % Mode



On the mode of Auto%, the wall controller will adjust fan speed and pump's work to maintain relative humidity.

When the mode switches to Auto%, the icons of Auto%, fan and cool will be shown on

screen, fan and cool functions will be turn on automatically, use  button to change speed.

As show in picture 7-6, current relative humidity is 56%, pre- concerted relative humidity is 60%, fan and cool functions been turned on.

The default temperature on Auto% mode is 60%, if you want to change that, then press

 button, the pre- concerted temperature flashes, use  buttons to change, press

 button again, this will finish the setting (as shown in picture 7-8). The relative humidity has been change to 57%.

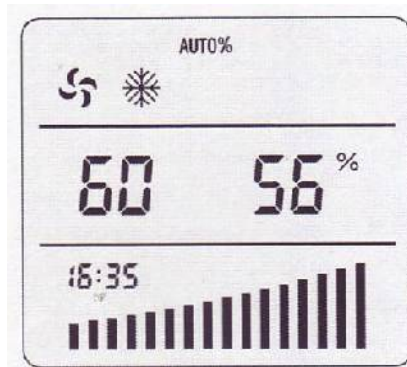

Picture 7-6 AUTO% mode

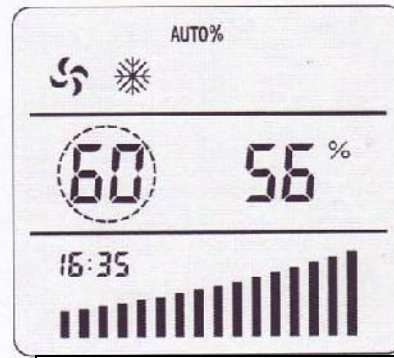

Picture 7-7 setting relative humidity

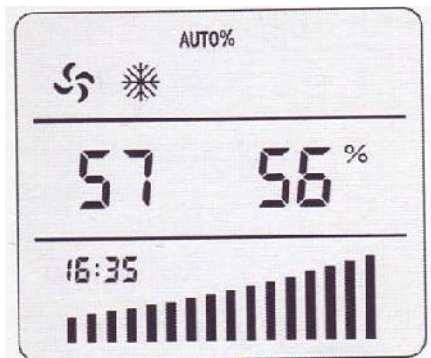

Picture 7-8 Finish the setting







## 8. Timer

Timer function can turn on/ off timing, the controller will work according to last setting before shutdown.

Timer function can work on any work modes, the setting methods are the same, take an example of manual mode (manual).







### 8.1 Timing Turn On

The processes are as follows:

1. Press the  button, and the screen will show "--:--" and "ON", means timing turn on functions haven't been set.
2. Press  button, --:-- changes to the current time 16:35, the hour is flashing, use  button to change hours;
3. Then press  button, the hour will stop blinking, the minutes are flashing, use  button to changes the minutes;
4. Press  button once again, to finish the setting, the screen shows the current time 16:35, "ON" means the timing turn on function is finished.





## 8.2 Timing Turn Off

The processes are as follows:

1. Press the  button, and the screen will show “18:40” and “ON”, means the time of turn on is 18:40
2. Press  button, and the screen will show “--:--” and “OFF”, means timing turn off function haven’t been set;
3. Then press  button “--:--” changes to current time, the hour is flashing, use  button to change hours;
4. Press button , the hour will stop blinking, the minute is flashing, use  button to change minutes
5. Press  button once again, finish the setting, the screen shows the current time “16:35”, “ON” and “OFF” flashing together, means the timing turn on/ turn off functions are finished.

## 8.3 Cancel Timing

The processes are as follows:

1. Press the  button, the screen shows “18:40” and “ON”, means the time of turn on is 18:40
2. Press  button, again the screen shows “23.30” and “OFF”, means time of turn off is 23.30
3. Then press  button, the screen shows “--:--” “ON” and “OFF”, means timing been cancelled
4. Press  button, timing been cancelled, the screen just show current time 18.35, no timing setting.

## 9. Backlight

Press any buttons to light the screen backlight on wall controller, the backlight will stay on for 30 seconds.

## 10. Suggestions

### 10.1 Fan Icon Flashing

When the Fan icon is flashing, that means, the air cooler is pre- cooling, the display will resume after finishing the pre- cooling action.

### 10.2 Cool Icon Flashing

Cool icon flashing (as show in picture 10-2), indicates the water tank has low water level. In order to protect the pump, please turn the pump off, and turn the pump on again after it has finished filling with water.

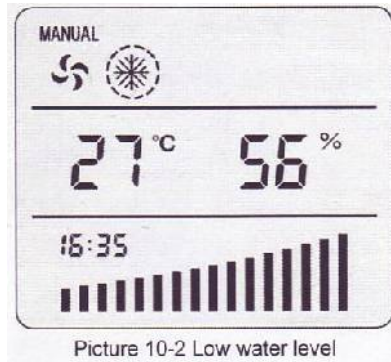



## 11. Advanced Settings

### 11.1 Pre- Cooling Mode

If your wall controller is designed to allow for the saturation of the cooler's cooling pads before the fan is switched on.

The default of pre- cooling mode is closed.

On the state of shutdown, press the buttons of  and  for 5 seconds, this can open or close the cooling mode. If the cooling mode is enabled, press the  button, the cooler will operate as follows:

1. If the tank is empty, the drain system will be closed. The tank will then be filled. Fan icon flashes on the screen.
2. 2 minutes later, the tank will start filling with water, the pump will turn on and saturate the filter pads. If the water tank still low in water, the pre- cooling action will be closed, and fan will start.
3. After the pump has been running for 1 minute, the pump will shut down, the fan will start, and the fan icon will be running on the screen.



Note 1: Pre- Cooling mode will not be activated if fan is selected on the wall controller, or the cooler is used again shortly after having been turned off.

Note 2: The setting of Pre- Cooling mode will be stored automatically and used at the next reboot.

## 11.2 Intelligent Cleaning Mode

**Note: This feature does not apply to all models; it will only effect those Sierra Products evaporative air coolers with EXHAUST function. We suggest you consult with your supplier before you operate this setting.**

If your wall controller is designed to intelligent cleaning mode, when cleaning the air cooler, the motor will run by contraries, and cooler pad has been soaked. The default of intelligent cleaning mode is closed

On the state of shutdown, press the buttons of  and  for 5 seconds, this can open or close the intelligent cleaning mode.



If intelligent cleaning mode is enabled, press the  button, the cooler will operate as follows:

1. The motor will run by contraries and exhaust. If the current air cooler is venting, the venting function will stop. 25 seconds later, exhaust function will be opened automatically. If the cool function is working at this moment, the drain valve will be turned on automatically, or else, no action on drain valve.
2. 5 minutes later, the drain valve will self- close (if been opened), air cooler resumes to the state before cleaning.

Note: The setting of intelligent cleaning mode will be stored automatically and used at the next reboot.

## 11.3 Shut Down Cleaning mode

If your wall controller is designed to shutdown cleaning mode, the cooler will open the clean function automatically when shutdown. The default of cleaning mode is closed.

On the state of shutdown, press the button  off and  for 5 seconds, this will open or close the shutdown cleaning mode.

If shutdown cleaning mode is enabled, turn the cooler off, the cooler will operate as follows:

1. All functions will be stopped except the clean function, CLEAN icon shown on wall controller.
2. 5 minutes later, cleaning function will turn off automatically. The screen does not display any information.

Note: the setting of shutdown cleaning mode will be stored automatically and used at the next reboot.

## 12. Malfunction

### 12.1 E1

“E1” Flashing (as shown in picture 11-1), indicates, the power supply to air cooler is over current please turn the power off, and check the power supply.

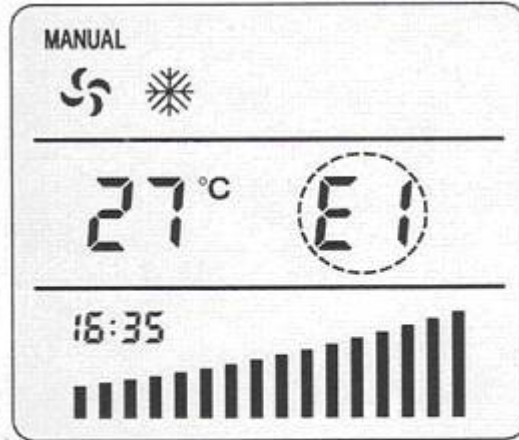

Picture 11-1 **check power supply**

### 12.2 E2

“E2” flashing indicates, the voltage supply to air cooler is over- voltage (larger than 265V). Please turn the power off, and check the power supply.

### 12.3 E3

“E3” Flashing indicates, the voltage supply to air cooler is under- voltage, (lower than 140V or phase failure). Please turn the power off, and check the power supply.

### 12.4 E8

“E8” Flashing indicates, the wall controllers can't receive the signal from the air cooler, try to pull out the signal line, and re- plug, pay attention to the good contact on communication interface.

### 12.5 E9

“E9” flashing indicates, the failure in water supply, if the water supply action can't be finished within 15 minutes, please turn the cool function off, and check the water supply system.

Restart the cool function, the machine will add water again, that can solve the water failure caused by reduced water flow.

### Maintenance

1. It is to be noted to change the water while the cooler is in work to avoid incrustation.
2. The filter pads should be cleaned more often to keep the cooling efficient. Do not use water above 40°C. Banister brush can be used softly to scrub away the dust on the pads.
3. The water supply should be shut off to avoid bacteria in the off season, it is also recommended covering to protect the cooler.

### Cleaning

1. All the models of this series has the function of auto timing cleaning. (the cooler will operate auto cleaning function after accumulative 8 hours under persistence power supply)
2. We recommend to clean the pad every month to keep the cooler operating efficiency.

### Water And Power Supply.

1. The water must be clean, tap water and water pressure should be more than 1.0kgs/cm.
2. There should be a stop valves in the hose and obligate the pin joint.
3. Keep the voltage only between 210-250v.
4. There should be a safety switch to prevent leakage. It also should avoid short circuit, overload and electric shock.

### Temperature And Evaporative Air Cooler

	Relative Humidity%								
Vent	10	20	30	40	50	60	70	80	90
Outside°C									
10	3.2	4.0	4.8	5.6	6.4	7.2	8.0	8.6	9.4
15	6.6	7.8	8.8	9.8	10.8	11.7	12.6	13.4	14.3
20	10.1	11.4	12.8	13.9	15.2	16.2	17.2	18.2	19.2
25	13.4	15.0	16.6	18.0	19.4	20.6	21.8	22.9	24.0
30	16.6	18.6	20.4	22.0	23.6	25.0	26.4	27.7	28.9
35	19.8	22.2	24.2	26.2	28.0	29.6	31.0	32.4	33.7
40	23.0	25.6	28.1	30.4	32.3	33.9			
45	25.9	29.2	32.0	34.3					
50	29	32.7	35.8						

## Trouble Shooting

The following troubleshooting guide is intended to address the most common symptoms and is by no means exhaustive. If symptoms persist, call a qualified serviceman. Only a certified electrician should complete electrical work. Turn off all power to the cooler before attempting to troubleshoot any of following symptoms.

Number	Symptom	Problem Cause	Remedy
1	Unit fails to start or deliver air	No electrical power to unit:- -Fuse blown -circuit breaker tripped -GFCI tripped  -Cords unplugged or damaged.  Motor overheated →  Motor frozen →  Motor able to free spin→	Check power:  Replace fuse Reset breaker Reset GFCI Plug in cord or replace if damaged  Try restart after cool down  Replace motor  Replace capacitor.
2	Unit starts but air delivery inadequate	Insufficient air exhausts →  Insufficient water- pad not wet:  - Cooling pads plugged - Dry streaks on pad  -Large dry spots on pad  -Pump not working  -Loose water connections	Open windows or doors.  Check water distribution system:  Clean or replace pads Check water level  Make sure cooler is level  Clean or replace pump  Check for leaks & correct.
3	Musty or unpleasant odor	Stale or stagnant water in sump→ Pads mildewed or clogged→  Pads not completely wet before cooler is turned on→	Drain flush and clean sump Replace pads  Turn on pump before starting fan
4	Knocking, shaking or rattling sounds	Loose parts→ Blower wheel loose or rubbing→	Check and tighten where needed  Inspect and adjust, or replace
5	Water droplets in the discharge air stream	Too much water delivered to the cooling pads→     Out door humidity level is too high or it is raining→	Make sure pads are properly positioned in the pad frames and the unit is level. If necessary, reduce the flow of water to the pads by tightening the screw on the hose restrictor clamp found on the pump discharge hose.  Use cooler as fan only (turn pump off) or discontinue use of cooler until outdoor humidity level drops.

## Warranty

Sierra products Pty Ltd air coolers extends 3 years part and labour for domestic installations and 1 year parts and labour for commercial installations limited warranty to the original purchase of a evaporative air cooler operated under normal conditions.

1. One year coverage applies to all components and accessories furnished by sierra products company. At our option, we will exchange or repair parts which fails due to non-conformance or material or workmanship during the first 3 years from the date of initial purchase for domestic customers and 1 year for commercial customers.
2. What this warranty does not cover:
  - a. This warranty does not cover any failure or damage resulting from unauthorized modification or service; or from the use of products or replacement parts other than those from sierra products; including, but not limited to, motors and pumps.
  - b. This warranty does not cover any damage or malfunction unless caused by a non- conformance in material or workmanship. Damage or malfunction which is not cover by this warranty includes, but is not limited to, water damage to the motor, abuse, misuse, alteration, improper installation/ maintenance/ operation, and transportation damage.
  - c. Mineral accumulation, dirt and dust on the pad are not defects and are excluded from this warranty. Refer to the owners manual supplied with your cooler for maintenance instructions to help minimize these conditions.
  - d. This warranty does not cover cost of a service call at the site of installation to diagnose cause of trouble, the cost of labor to install the part, or mileage allowance to or from the site. Sierra products does not pay freight or postage on any exchange.

- Do not use cooler cleaner, cooler treatments, or other additives in this evaporative cooler. The use of any other products will void your warranty and may impair the life of your evaporative cooler.

- To obtain service under this warranty, contact the dealer where you purchased your evaporative cooler. As a final step, if you cannot locate your dealer, contact customer service at Sierra products. Include your name, address and post code, the model number and serial number of your evaporative cooler, date of installation, and description of your problem.

This warranty is the only warranty extended by Sierra Products to suppliers and/ or purchases of this evaporative cooler. Sierra Products disclaims all other warranties, express or implied that arise by the operation of the law, except that implied warranties of merchantability or fitness for a particular purpose are limited to the duration of the warranty period. Sierra products shall not be liable for any incidental or consequential damage which may have resulted from any alleged breach or warranty.

Some states do not allow limitations on how long an implied warranty lasts or the exclusion or limitation or incidental or consequential damages. So the limitations or exclusions stated above may not apply to you.

This warranty gives you specific legal right and you may have other rights, which vary from state to state, since Sierra Products company, follows a policy of continuous products improvement; it reserves the right to change design and specification without prior notice or liability.